

P R E M I U M D R A W E R S



N O T P R E M I U M P R I C E T A G S

harn[®]
RITMA  cube



DORSET
AUSTRALIA

DESIGNED TO SATISFY ANY CLIENT'S IMAGINATION

We know that your kitchen & joinery projects demand solutions that are as unique and varied as your clients. No two projects are identical, and that's why we have developed a versatile range that gives you the options and choice to deliver the perfect solution to your customer's requirements.

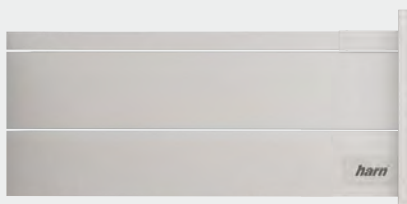
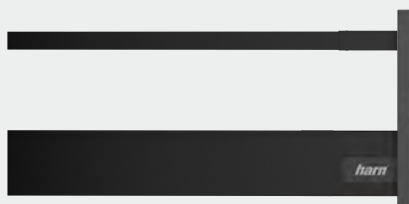
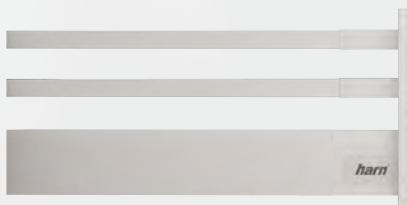
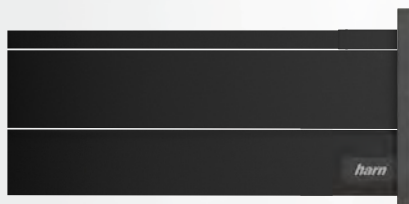

SOFT CLOSE DRAWERS THAT HELP CLOSE THE DEAL



Not only does the Harn RITMA Cube range incorporate a vast array of options to suit every joinery project, but these drawers are surprisingly good value, bringing the very best in soft-close drawer systems to your clients at a price that will help you close the deal!

NOW THE CHOICE IS YOURS

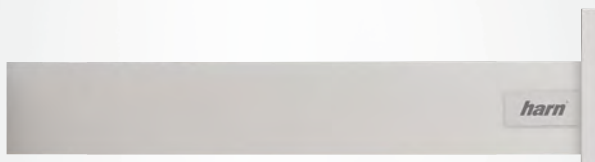

S Drawer - 83mm

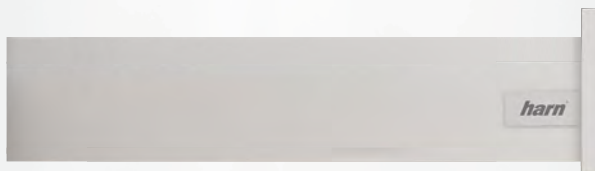

T Drawer - 115mm

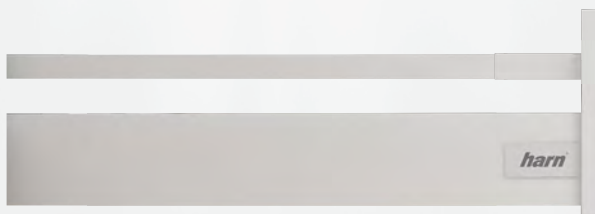

MS Drawer - 135mm

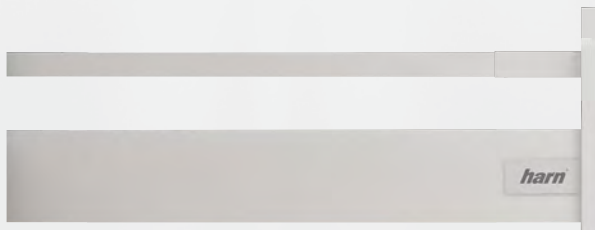

KS Drawer - 167mm

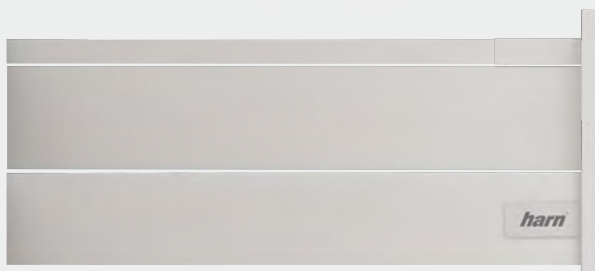

HS Drawer - 199mm

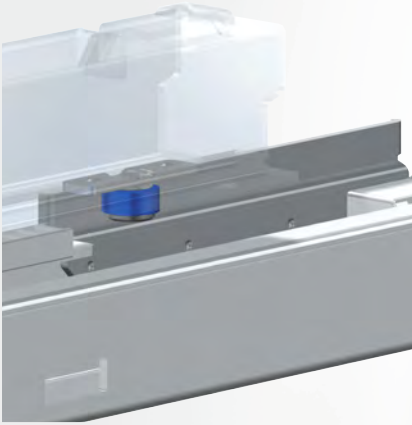

STABLE

Anti-Skew Stability Mechanism

The Anti-Skew feature is seamlessly incorporated in to the rear Harn RITMA Cube cabinet member.

This feature ensures that the drawer doesn't skew by using a system whereby a small roller runs along a guide keeping the drawer aligned in the initial stages of opening.

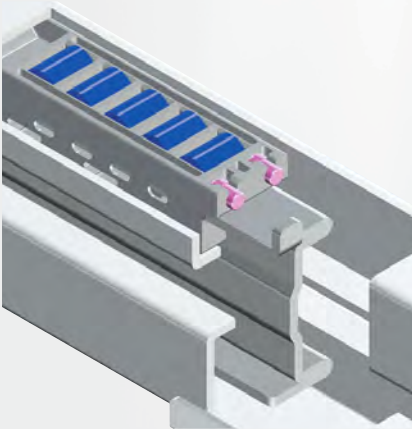

STRONG

I-Beam

The unique I-Beam is a proven strength of the Harn RITMA Cube Drawers.

Not only does the I-Beam provide additional strength it also allows for the nests of roller bearings to have increased contact surface area between the separate parts of the cabinet member, ensuring a smoother and quieter sliding performance under full load.

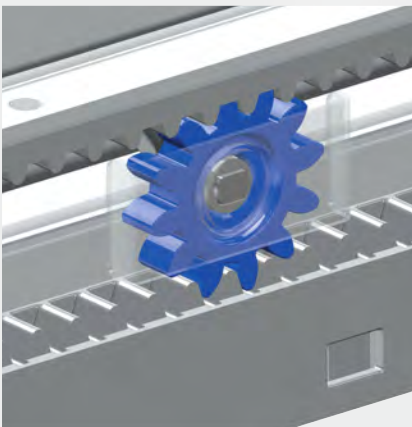

SMOOTH

Synchronised Runners

The Synchronisation Mechanism is a new addition to the Harn RITMA Cube drawer cabinet member.

It keeps the parts of the cabinet member running in perfect unison, ensuring an even and controlled closing motion. This is achieved through the use of a dual rack and pinion system cleverly integrated into the side of the cabinet member.

DRAWER OPTIONS

LENGTH OPTIONS



FINISH OPTIONS

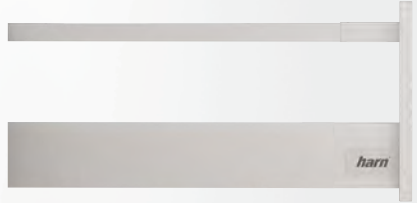

White (WH)

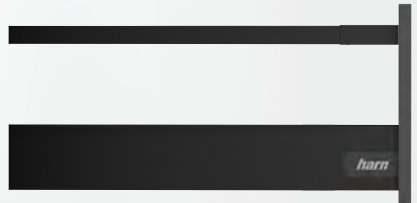

Jet Black (JBL)

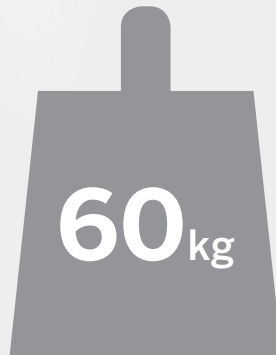

THE CHOICE FOR SOME OF AUSTRALIA'S LEADING PROJECTS

Quest Apartments, Port Adelaide

Cabinet Maker: Spry & Spry Pty Ltd -

Architectural Cabinetmakers

Project Value: \$25M

Size: 105 Apartments



Derby Place, Kew VIC

Address: 369 High

Street, Kew VIC

Cabinet Maker:

Marant Industries

Size: 77 Apartments

Builder: Crema

Constructions

Architects: Fender

Katsalidis & CBG

Architects

Developer: Crema

Group



Holmes Hill, Chadstone VIC

Address: 70 Batesford Road,

Chadstone VIC

Cabinet Maker: Archibuild Commercial

Project Value: \$45M

Size: 212 Apartments

Builder: ABD Group

Architect: Buchan Group

Developer: CBD Development

Group



FIND OUT MORE ABOUT
PREMIUM DRAWERS

NOT PREMIUM PRICE TAGS

FOR MORE INFORMATION
WWW.DORSETAUSTRALIA.COM.AU

CALL 1300 121 800
TO BOOK AN APPOINTMENT



Lifetime
Warranty



On Time,
Every Time



No Good?
No Worries!

harn[®]
RITMA  cube



DORSET
AUSTRALIA